



350 S. St. Charles St. Jasper, In. 47546

Ph. 812.482.2932 Fax 812.634.6632

[www.ridetech.com](http://www.ridetech.com)

**Part # 11030399**  
**55-57 Chevy Level 3 Street Challenge Package**  
Two Piece Frame

**Front Components:**

1	11013011	TQ Series Front Shockwaves
1	11012899	Front Lower StrongArms
1	11013699	Front Upper StrongArms
1	11019300	2" Drop Spindles w/ Mounting Brackets
1	11019100	Front MuscleBar Sway Bar w/ PosiLinks
1	11019400	Billet Tie Rod Adjusters

**Rear Components:**

1	11037199	Rear AirBar 4 Link
1	24340701	TQ Series Rear Shockwaves

**Compressor System:**

1	30314100	5 gallon AirPod w/ LevelPro
1	30400034	LevelPro Upgrade - 4 External Height Sensors
1	31008500	Two key fob remotes with antenna



350 S. St. Charles St. Jasper, In. 47546  
Ph. 812.482.2932 Fax 812.634.6632

[www.ridetech.com](http://www.ridetech.com)

**Part #11013011**  
**55-57 Chevy Car Front TQ Series ShockWaves**  
For Use w/ Lower StrongArms

**ShockWave Assembly:**

2	24090399	104mm Master Series rolling sleeve assembly
2	24349999	4" stroke TQ Series shock
2	90001994	.625" I.D. bearing
4	90001995	Bearing snap ring
2	90009988	Short Delrin stud top – 2"

**Components:**

2	90002312	Short Delrin stud top base – 2"
2	90001902	Aluminum cap for Delrin ball
2	90001903	Delrin ball upper half
2	90001904	Delrin ball lower half
2	31954201	¼"npt x ¼" tube swivel elbows
4	90002221	Reservoir Mounts
1	99050000	Allen Wrench for Reservoir Hardware

**Hardware:**

2	99562003	9/16" SAE jam nut	Stud top hardware
12	85000003	4mm Socket head	Reservoir hardware

# SHOCKwave<sup>®</sup>

by Air Ride Technologies

## Installation Instructions

1. Raise and support vehicle at a safe, comfortable working height. Let the front suspension hang freely.
2. Remove the coil spring and shock absorber. Refer to a factory service manual for proper disassembly procedure.

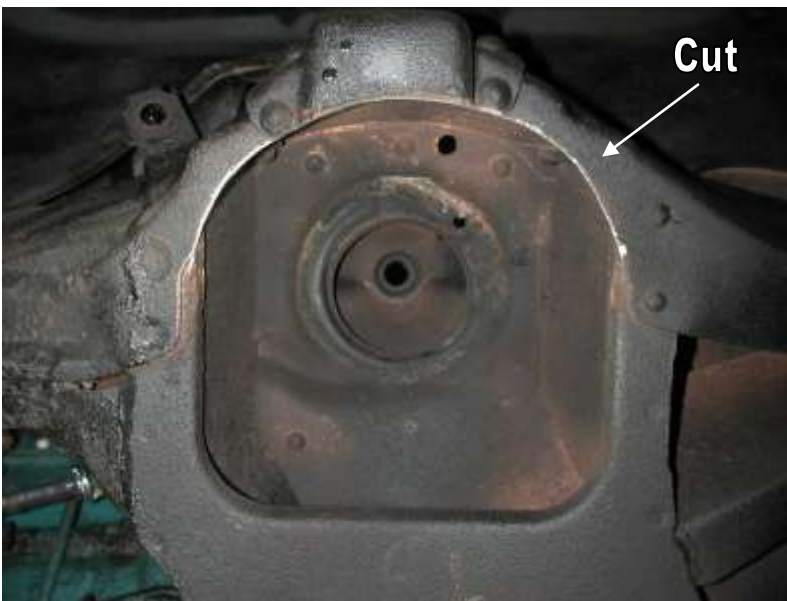

3. For air spring clearance some trimming must be done on the outer lip of the coil spring pocket. This is what it should look like after cutting.

4. This is best done with a cut off wheel or plasma cutter. Grind all cuts smooth when finished.

**Allowing the shockwave will rub will result in failure, this is not a warrantable situation.**

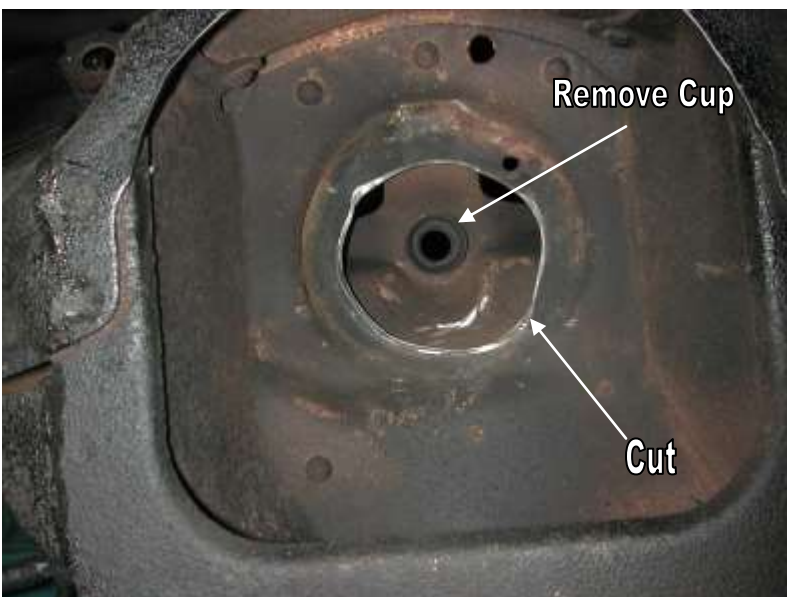

5. The domed portion of the Shockwave will hit the coil spring retainer. This lip must be removed.

6. The factory upper bushing cup must also be removed.

7. Apply thread sealant to a 90 degree air fitting and screw it into the top of the Shockwaves. The fitting location can be rotated by twisting the bellow while holding the shock body.



8. Place the Shockwave up into the coil spring pocket with the stud protruding through the factory shock hole. See diagram below. The factory shock hole may need to be drilled out to  $\frac{3}{4}$ ".

9. Fasten the Shockwave to the factory lower control arm using the  $\frac{1}{2}$ " x  $3\frac{1}{4}$ " bolt, Nylok nut & aluminum spacers supplied w/ the StrongArms.

10. Ride height will be around 90-100 psi, but will vary to driver preference.

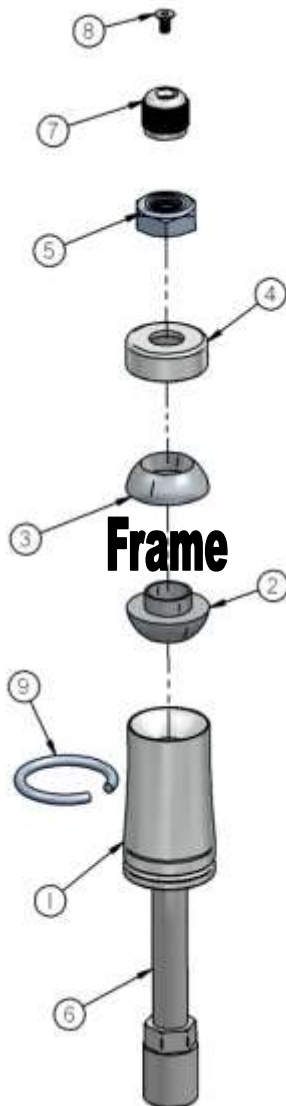

1. Stud top base
2. Lower Delrin ball half
3. Upper Delrin ball half
4. Aluminum cap
5. 9/16" Nylok jam nut
6. Threaded stud
7. Adjustment knob (SA Only)
8. Screw
9. Snap ring (Coil Over Only)



350 S. St. Charles St. Jasper, In. 47546  
Ph. 812.482.2932 Fax 812.634.6632  
[www.ridetech.com](http://www.ridetech.com)

**Part # 11012899**  
**55-57 Chevy Car Lower StrongArms**  
For Use with Shockwaves or CoilOvers

**Components:**

- |   |          |                                                                |
|---|----------|----------------------------------------------------------------|
| 1 | 90000561 | Driver side lower control arm                                  |
| 1 | 90000562 | Passenger side lower control arm                               |
| 2 | 90000916 | Lower ball joint (includes boots, castle nuts and cotter pins) |
| 4 | 90000906 | Lower control arm bushing                                      |
| 4 | 90002062 | Aluminum spacers for Shockwaves                                |

**Hardware:**

- |   |          |                         |                        |
|---|----------|-------------------------|------------------------|
| 2 | 99501024 | ½"-13 x 3 ¼" Gr. 5 bolt | ShockWave to lower arm |
| 2 | 99502001 | ½"-13 Nylok nut         | ShockWave to lower arm |

## Installation Instructions

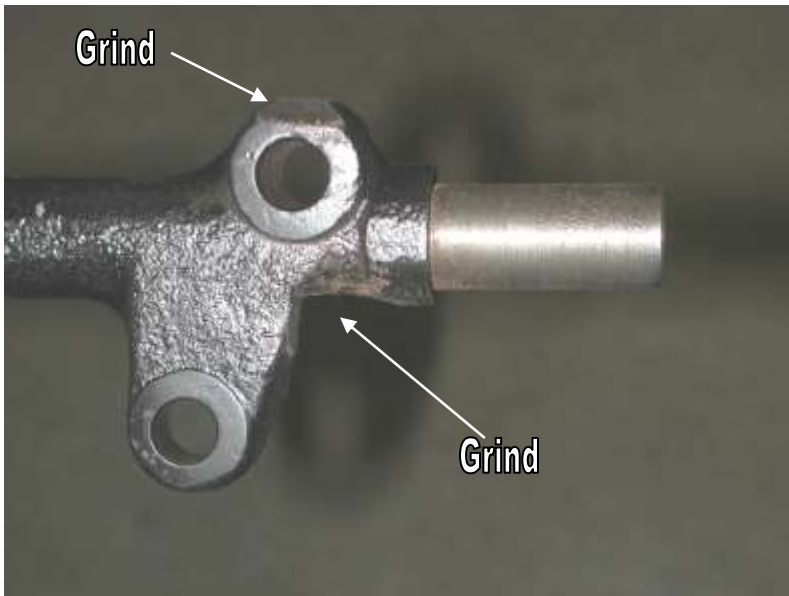

1. Remove factory cross shafts from lower arm and install the factory cross shaft onto the lower StrongArm using the factory hardware. Some grinding must be done on the cross shaft to be able to slide it into the StrongArm. Replacement bushings are provided.

**Note:** There is a driver and passenger side lower cross shaft. The extended length of the shaft should go to the front of the vehicle.



2. Install the ball joints in the lower arm pointing down.

3. Bolt the lower StrongArm to the car using the oem bolts. Note that the sway bar mount will face toward the front of the vehicle.



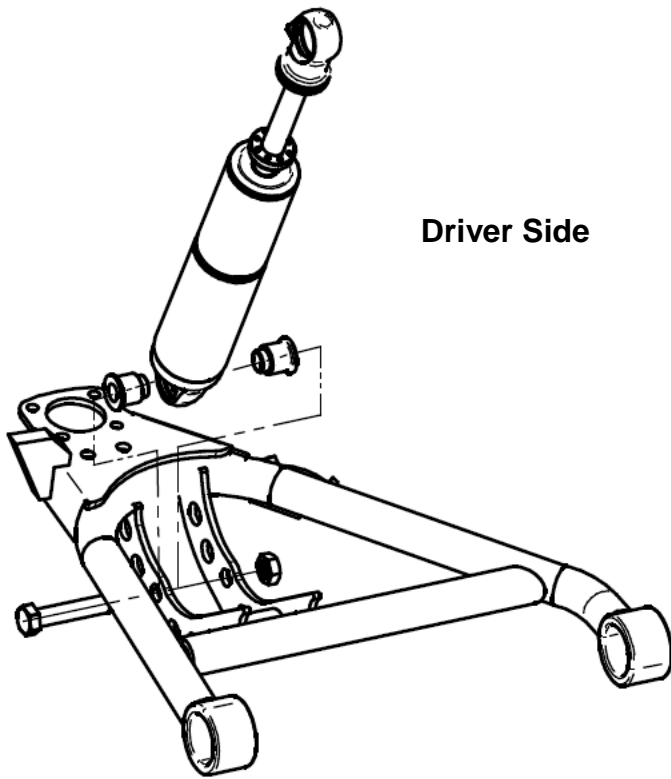

4. Bolt the Shockwave or CoilOver to the lower arm using the supplied 1/2" x 3 1/4" bolt and Nylok. An aluminum spacer on both sides of the eye will center the Shockwave.

**Note:** There are holes on the lower arm near the ball joint to mount the factory bump stop. Although, it is not needed unless you are having tire clearance issues.

5. Slide the ball joint through the spindle and secure w/ castle nut and cotter pin.



6. Grease the ball joints.

7. Double check air spring clearance through full suspension travel. If any part of the Shockwave touches the frame at anytime it will damage the unit. **This is not a warrantable situation.**

# STRONG ARMS™

by Air Ride Technologies

Item #	Description	Qty.
1.	Passenger side arm	1
1.	Driver side arm	1
2.	Aluminum bearing spacer	4
3.	1/2"-13 x 3 1/4" bolt	2
4.	1/2"-13 Nylok nut	2
5.	Cross shaft bushing	4
6.	Ball joint	2
7.	5/16"-24 nut	8
8.	5/16"-24 x 3/4" bolt	8

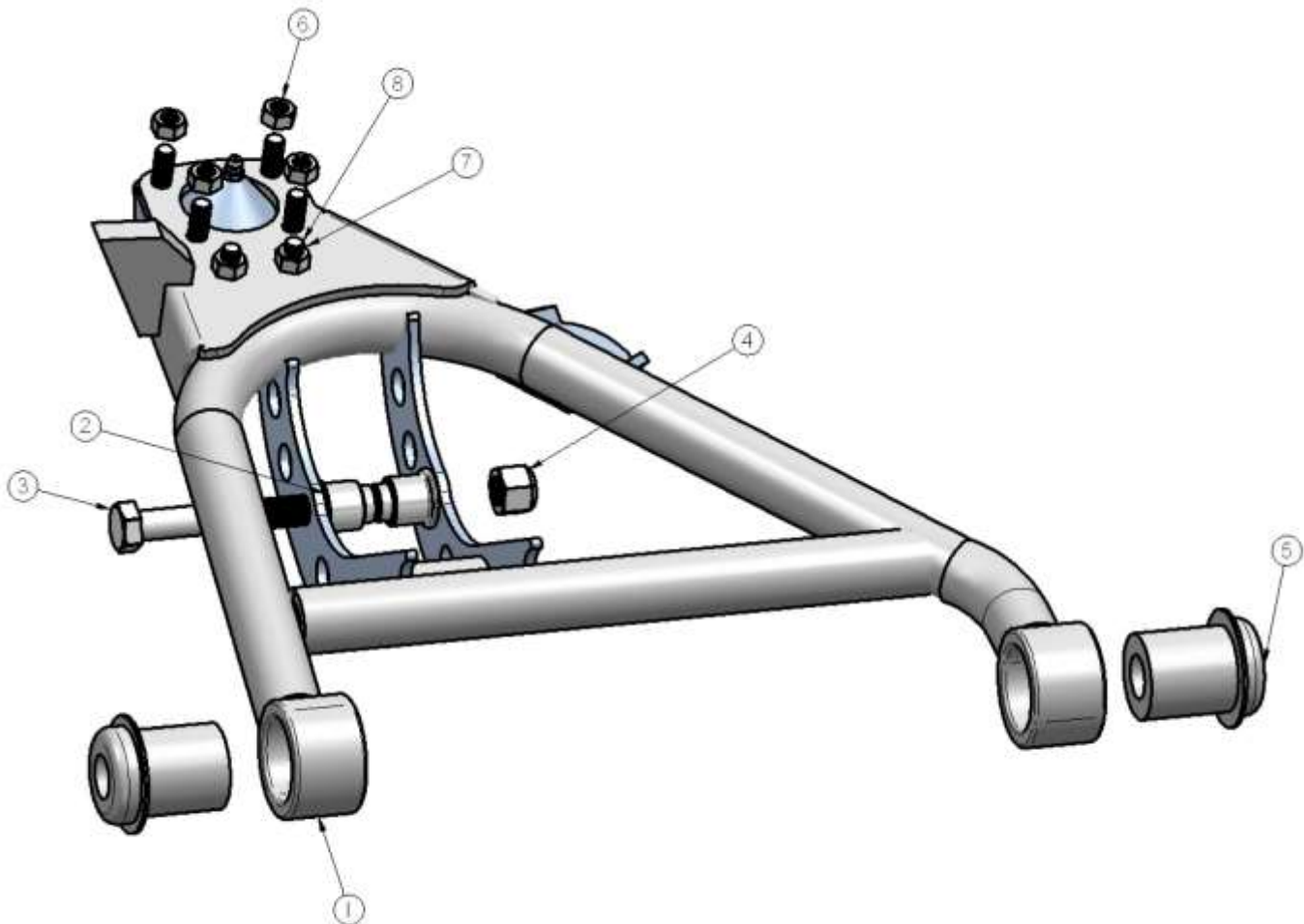





350 S. St. Charles St. Jasper, In. 47546  
Ph. 812.482.2932 Fax 812.634.6632  
[www.ridetech.com](http://www.ridetech.com)

**Part Number 11013699**  
**55-57 Chevy Upper StrongArms**

**Components:**

1	90000541	Driver side upper arm
1	90000542	Passenger side upper arm
2	90000905	Ball joint (includes boot, grease fitting, castle nut & cotter pin)
4	90000907	Cross shaft bushing
4	90000543	Upper cross shaft large sleeve
4	90000544	Upper cross shaft small sleeve

**Hardware:**

4	99371015	3/8"-24 x 1 1/2" bolts	Upper cross shaft
4	99373005	3/8" lock washers	Upper cross shaft

## Installation Instructions



1. Remove the upper control arm and cross shaft. The factory cross shaft will be reused.

2. Place the larger sleeve over the end of the upper cross shaft, slide the cross shaft through the StrongArm. Then press the bushing over the shaft. Insert the smaller sleeve inside the bushing and tighten the assembly with the 3/8" - 24 x 1 1/2" bolts.

3. Install the ball joint into the upper StrongArm also facing down.



4. Bolt the upper StrongArm to the frame and spindle using the factory frame bolts.

5. The upper control arm bump stop is reused.

6. Grease the ball joints.

## 55-57 Chevy Upper StrongArm

Item #	Description	Qty.
1.	Passenger side arm	1
1.	Driver side arm	1
2.	Ball Joint	2
3.	Upper Cross shaft Large Sleeve	4
4.	Cross shaft bushing	4
5.	Upper Cross shaft Small Sleeve	4

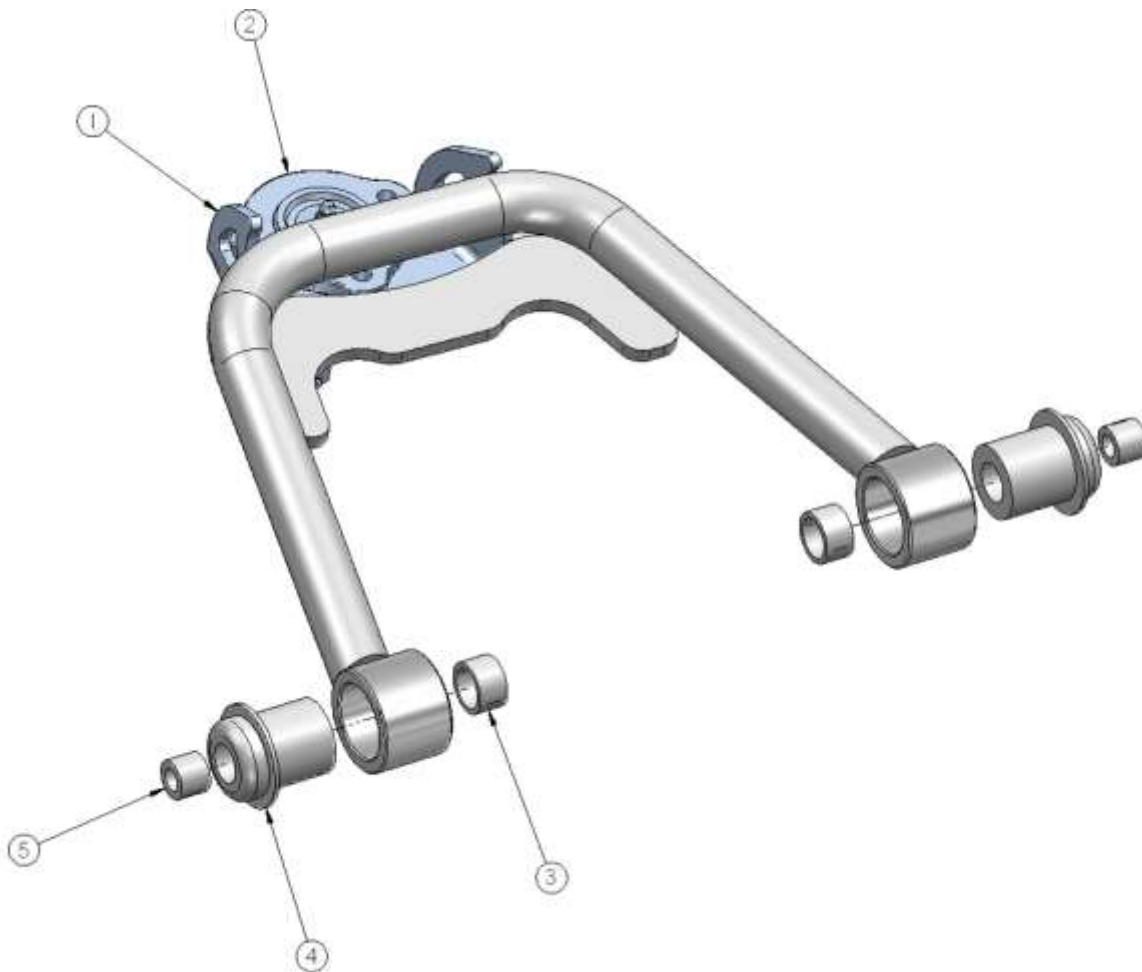



350 S. St. Charles St. Jasper, In. 47546  
Ph. 812.482.2932 Fax 812.634.6632  
[www.ridetech.com](http://www.ridetech.com)

**Part # 11019300**  
**55-57 Chevy 2" Drop Spindles**

2      11019301      2" Drop Spindle

**Note:** These drop spindles are designed to work with 79-81 GM "A" Body or 82-92 S-10 rotors. They are compatible with several different caliper arrangements. Heidt's Hot Rod shop offers caliper brackets to fit 69-72 GM "A" Body/78-81 Camaro calipers and 78-87 GM "G" Body/82-92 S-10 calipers. They also offer calipers and brackets for Wilwood brakes. Baer Racing offers caliper bracket for their brakes as well.



350 S. St. Charles St. Jasper, In. 47546  
Ph. 812.482.2932 Fax 812.634.6632  
[www.ridetech.com](http://www.ridetech.com)

**Part #11019400**  
**55-57 Chevy Billet Tie Rod Adjuster**

2      90000730      9/16" x 5 1/2" Billet tie rod adjuster  
2      9/16" SAE **Right** hand thread jam nut  
2      9/16" SAE **Left** hand thread jam nut



350 S. St. Charles St. Jasper, In. 47546  
Ph. 812.482.2932 Fax 812.634.6632  
[www.ridetech.com](http://www.ridetech.com)

**Part # 11019100**  
**55-57 Chevy Front MuscleBar**

**Components:**

1	90000731	Sway Bar
2	90001100	Bushing and strap kit
2	90000729	Frame plate
4	90000717	Aluminum step washer
2	90000924	10mm straight PosiLink
2	90000926	10mm 90 degree PosiLink
1	90001092	Tube of lithium grease

**Hardware:**

2	10mm x 1.5 stud	PosiLink (use Loctite)
2	10mm lock washer	90 degree PosiLink
2	10mm Nylok nut	Straight PosiLink
8	3/8" x 1 1/4" USS bolt	Frame plate
8	3/8" USS Nylok nut	Frame plate
18	3/8" SAE flat washers	Frame plate & PosiLink

**MUSCLEbar™**

# POSI • Link™

## SWA7500 Installation Instructions

This sway bar is designed for use with Air Ride Technologies StrongArms.



1. The sway bar frame plate will index off of this factory support brace rivet. Remove the rivet by grinding the head smooth, then drive it out with a hammer and punch.

2. Drill hole to 3/8".



3. Using a 3/8" x 1 1/4" bolt, flat washer and Nylok nut, bolt the frame plate to the bottom of the frame rail.

4. Make sure the side of the plate is aligned with the outside of the frame rail. Drill the remaining holes.

5. Bolt the outside rear hole of the plate to the frame using a 3/8" x 1 1/4" bolt, Nylok nut and flat washer.





6. Apply lithium grease to the poly bushing. Install the bushing over the sway bar, and then place the bushing strap over the bushing.

7. Bolt the sway bar to the frame plate using two 3/8" x 1 1/4" bolts, Nylok nuts and flat washers. Do not tighten yet.



8. Bolt the 90 degree end of the PosiLink to the sway bar. A 3/8" flat washer and 12mm lock washer must be installed between the PosiLink and the bar.

9. Bolt the straight end of the PosiLink to the lower control arm. An aluminum step washer must be installed on each side of the control arm tab. Fasten with a 12mm Nylok nut. Then tighten the bushing frame bolts.



Your MuscleBar installation is now complete. If you have any further questions, please call our technical support line at 812-482-2932.



350 S. St. Charles St. Jasper, In. 47546  
Ph. 812.482.2932 Fax 812.634.6632

[www.ridetech.com](http://www.ridetech.com)

**Part # 11037199**  
**55-57 Chevy Rear AirBar**  
**(Two Piece Frame)**

**Components:**

1	90000160	Driver side lower axle bracket
1	90000558	Passenger side lower axle bracket
1	90000557	Front cross member (35.125")
1	90000554	Upper shock mount
1	90000555	Upper shock mount
4	90000552	Heim end spacer for diagonal bar
1	90000550	Lower shockwave mount
1	90000551	Lower shockwave mount
8	90001942	Pressed into bars
4	90000956	Parallel Bars C-C 18.50"
1	90000941	Diagonal bar C-C 30.25"
2	90001617	5/8" Shock studs
1	90000266	Brake line tab
4	90001584	Rod end
2	90001589	Heim end for Diagonal link
6	99752004	3/4"-16 Hex jam nut for rod ends
4	90002067	Aluminum spacers – lower shock bearing

**Hardware Kit Part # 99010019:**

4	1/2" x 3/4" Gr. 8 bolt	Lower Shockwave Mount
10	5/8" SAE Gr.8 Nyloc Jam nut	Rod ends
8	5/8" x 2 3/4" SAE Grade 8 bolt	Bar ends
2	5/8" x 3" SAE gr.8 bolt	Bar ends with diagonal link mounts
2	1/2" x 2 1/4" SAE bolt	Upper Shockwave mount
2	1/2" SAE Nyloc jam nut	Upper Shockwave mount
20	3/8" x 1" type F thread forming bolt	Crossmember and upper Shockwave mount
20	3/8" Lock washer	Crossmember and upper Shockwave mount
2	#10 x 3/4" Tek screws	Brake line bracket

# **AirBAR**<sup>®</sup>

by Air Ride Technologies

1. Raise the vehicle to a safe and comfortable working height. Use jack stands to support the vehicle with the suspension hanging freely.
2. Support the axle and remove the leaf springs, shocks, bump stops, pinion snubber and tail pipes. Refer to the factory service manual for proper disassemble procedures.



3. The parking brake brackets will be in the way of the 4 link and must be removed. Loosen the parking brake adjustment nut and remove the cable from the frame bracket. The tack weld can be broke loose with a hammer and chisel. Grind the remains of the weld smooth.



4. The rear brake line bracket on the passenger side frame rail must also be removed. Be careful not to cut fuel line.





5. Use a couple clamps to secure the crossmember between the frame rails. Slide it forward to the edge of the body mounts. Drill the holes with a 5/16" bit and thread the 3/8" x 1" self-tapping bolts in one at a time.

**Do not over tighten the self-tapping bolts; they can be stripped.**



6. The location of the upper Shockwave mount is determined by measuring 14 1/2" from the edge of the bracket to the large hole in the bottom of the frame.



7. Use a clamp to hold the bracket against the inside of the frame and drill the holes with a 5/16" bit. Thread a 3/8" x 1" self-tapping bolt into the frame after drilling each hole.

8. Note there is a driver and passenger side bracket and are stamped accordingly. When using the correct bracket the Shockwave will be perpendicular with the ground.

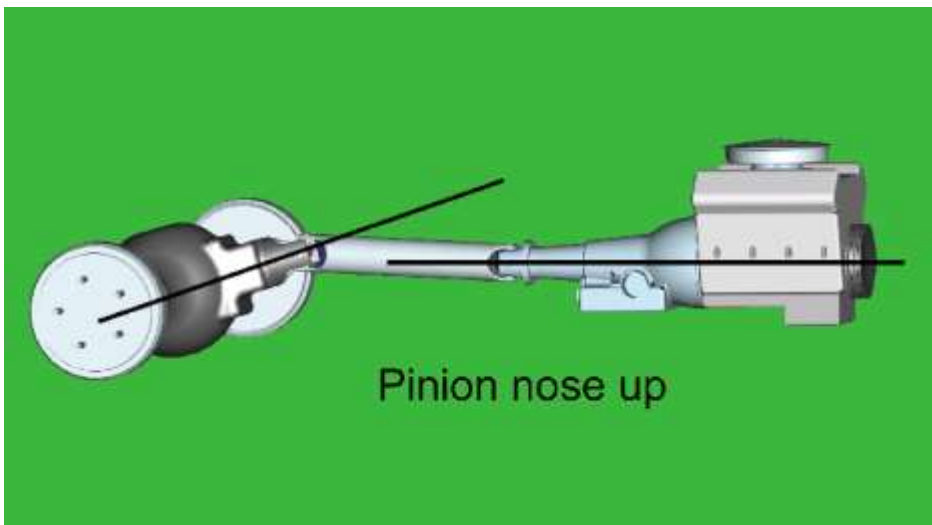
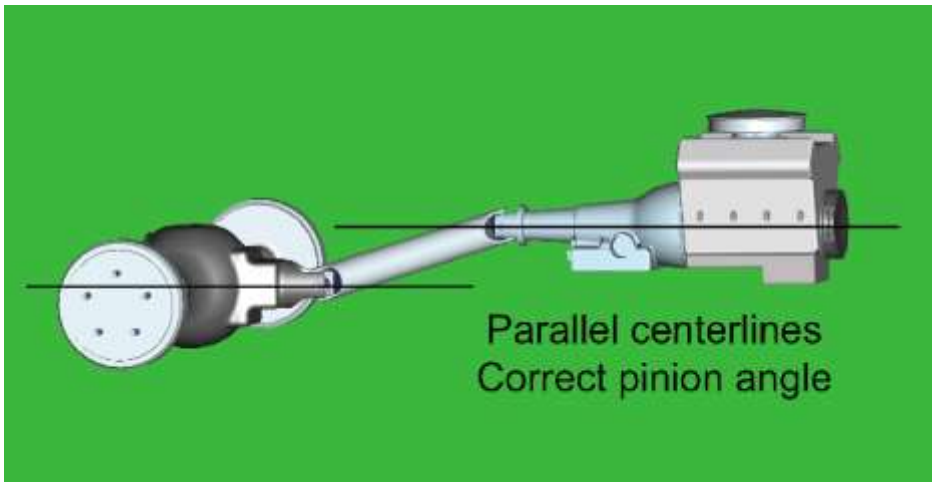
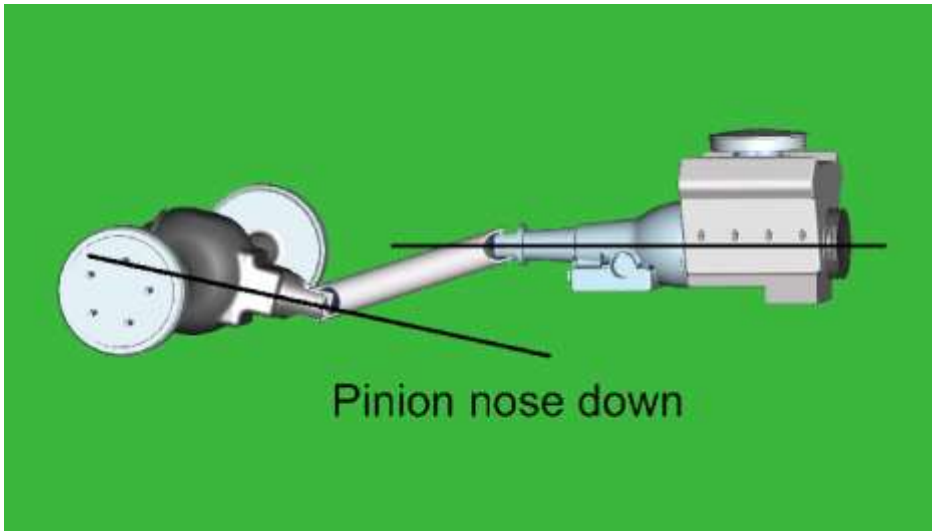

9. How do you set the pinion angle? On a single-piece shaft you want to set it up where a line drawn through the center of the engine crankshaft or output shaft of the transmission and a line drawn through the center of the pinion are parallel to each other but not the same line.

A simple way to do this is to place a digital angle finder or dial level on the front face of the lower engine pulley or harmonic balancer. This will give you a reading that is 90 degrees to the crank or output shaft unless you have real problems with your balancer. At the other end, you can place the same level or angle finder against the front face of the pinion yoke that is also at 90 degrees to the centerline. If you rotate the yoke up or down so both angles match, you have perfect alignment.

Road testing will tell you if you have it right. If you accelerate and you get or increase a vibration, then the pinion yoke is too HIGH. Rotate it downward in small increments of a degree or two until the problem goes away. If you get or increase a vibration when decelerating, then the pinion yoke is too LOW. Rotate it upward to correct it.





10. Pinion angle must be set at ride height. At ride height there should be 4 1/2" between the axle and frame.

11. One trick to help maintain these setting while welding in the axle bracket is to tack weld a 4 1/2" long spacer between the axle and frame.

12. After setting the pinion angle, make sure the axle is centered. This can done by measuring from the axle flange in to the frame rail.



13. Install the 4 link bars into the crossmember and axle bracket, but **do not tighten the bolts yet**. Use the 5/8" x 2 3/4" bolts and nylocs supplied. Check the length of the bars; they should be 18 1/2" C-C.

14. There is a driver and passenger side bracket. The passenger side bracket has the diagonal link bracket welded to it. These rod ends will use a 3" bolt. You can use a large hose clamp to hold these in place temporarily.



15. Swing the axle bracket up to the axle. These brackets must be centered and aligned with the crossmember mounts before welding. The brackets should be 31 5/8" apart on the outside measurement. Then just center it between the axle flanges.

16. Tack weld the bracket to the axle. Double-check axle center, bracket alignment, and pinion angle. Remove the bars to avoid frying the bushings. Then finish welding the bracket 1" at a time in different spots to avoid warping the axle.





17. Bolt the lower Shockwave mount to the axle bracket using the 5/8" x 3/4" Allen bolt. Apply anti-seize to the threads. It is easier to remove the bars to install these bolts.

18. There is a driver and passenger side bracket, the correct bracket will offset the Shockwave toward the wheel.



19. Bolt the diagonal link into place with a spacer on both sides of it using a 5/8" x 2 3/4" bolt and nyloc. It should measure 30 1/4" C-C.

20. Install the parking brake cable into the new tab on the crossmember.

21. With the axle at ride height snug all the 4 link bolts. These bushings are rubber and do not require lubrication.



22. Apply thread sealant onto the air fitting and screw it into the top of the shockwave. Air fitting location can be moved by rotating the bellow assembly separate from the shock.

23. Screw the stud into the lower billet mount. Place the washer over the stud then the Shockwave followed by another washer. Apply anti-seize to the threads and then nyloc nut.

24. The Shockwave/Coilover is held to the upper mount using a 1/2" x 2 1/4" bolt and nyloc.



**25. Remove the spacer from between the axle and frame.**

26. A new brake line tab is supplied and will mount just below the original. Make sure it clears the bar through full suspension travel.

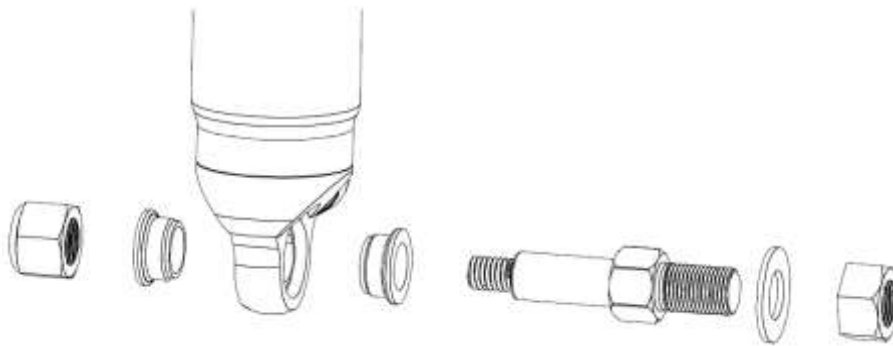

27. Driving height will be with approximately 13" from center eye to center eye.





350 S. St. Charles St. Jasper, In. 47546  
Ph. 812.482.2932 Fax 812.634.6632  
[www.ridetech.com](http://www.ridetech.com)

**Part # 24340701**  
**7000 Master Series TQ Series Shockwaves**  
Triple Adj. - 4" Diameter - 4" Stroke - .625" Bearing/.625" Bearing

Shockwave:

2	24349999	4" stroke TQ Series shock
2	24090799	7000 series Shockwave bellow assembly
2	90002024	Short eye mount (1.7" tall)
4	90001994	.625" I.D. bearing
8	90001995	Snap ring
2	70008913	Locking ring

Components:

4	90002044	Bearing spacer kit
2	31954201	1/4" npt x 1/4" tube swivel elbow fitting
4	90002221	Reservoir Mounts
1	85000003	Allen wrench for reservoir hardware

Hardware:

12	99050000	4mm Socket head cap screws	Reservoir Hardware
----	----------	----------------------------	--------------------

# **SHOCK**Wave<sup>®</sup>

by Air Ride Technologies

## 7000 Series Shockwave

Use these  
spacers when  
mounting on 5/8"  
bolt.



Compressed Height	10.6"
Ride Height	13"
Extended Height	14.6"

Use these spacers  
when mounting on  
1/2" bolt.



# SHOCKwave®

by Air Ride Technologies

## The care and feeding of your new ShockWaves

1. Although the ShockWave has an internal bumpstop, **DO NOT DRIVE THE VEHICLE DEFLATED RESTING ON THIS BUMPSTOP. DAMAGE WILL RESULT.** The internal bumpstop will be damaged, the shock bushings will be damaged, and the vehicle shock mounting points may be damaged to the point of failure. **This is a non warrantable situation.**
2. Do not drive the vehicle overinflated or “topped out”. Over a period of time the shock valving will be damaged, possibly to the point of failure. **This is a non warrantable situation!** If you need to raise your vehicle higher than the ShockWave allows, you will need a longer unit.
3. The ShockWave is designed to give a great ride quality and to raise and lower the vehicle. **IT IS NOT MADE TO HOP OR JUMP!** If you want to hop or jump, hydraulics are a better choice. This abuse will result in bent piston rods, broken shock mounts, and destroyed bushings. **This is a non warrantable situation.**
4. Do not let the ShockWave bellows rub on anything. Failure will result. **This is a non warrantable situation.**
5. The ShockWave product has been field tested on numerous vehicles as well as subjected to many different stress tests to ensure that there are no leakage or durability problems. Failures have been nearly nonexistent unless abused as described above. If the Shockwave units are installed properly and are not abused, they will last many, many years. **ShockWave units that are returned with broken mounts, bent piston rods, destroyed bumpstops or bushings, or abrasions on the bellows will not be warrantied.**

### Shock adjustment 101- Single Adjustable

#### Rebound Adjustment:

How to adjust your new shocks.

The rebound adjustment knob is located on the top of the shock absorber protruding from the eyelet.

You must first begin at the ZERO setting, then set the shock to a soft setting of 20.



-Begin with the shocks adjusted to the ZERO rebound position (full stiff). Do this by rotating the rebound adjuster knob clockwise until it stops.



-Now turn the rebound adjuster knob counter clock wise 20 clicks. This sets the shock at 20. (settings 21-24 are typically too soft for street use).

#### Take the vehicle for a test drive.



-if you are satisfied with the ride quality, do not do anything, you are set!



-if the ride quality is too soft increase the damping effect by rotating the rebound knob clock wise 3 clicks. CONTINUE ON NEXT PAGE.

**Take the vehicle for another test drive.**



-if the vehicle is too soft increase the damping effect by rotating the rebound knob clock wise 3 additional clicks.

-if the vehicle is too stiff rotate the rebound adjustment knob counter clock wise 2 clicks and you are set!

Take the vehicle for another test drive and repeat the above steps until the ride quality is satisfactory.

**Note:**

One end of the vehicle will likely reach the desired setting before the other end. If this happens stop adjusting the satisfied end and keep adjusting the unsatisfied end until the overall ride quality is satisfactory.

## Shock adjustment 101- Triple Adjustable

**Triple Adjustable:**

**Step One: High Speed Compression**



-High speed compression adjustments are used in both street driving and track tuning.

-Begin with the shocks adjusted to the ZERO high speed compression position (full stiff). Do this by rotating the high speed compression adjuster (large knob) clockwise until it stops.

-Now turn the high speed compression adjuster knob counter clock wise 20 clicks. This sets the shock at 20. (settings 21-24 are typically too soft for street use. For typical street driving the high speed compression adjuster will remain at setting 20.

**Step Two: Low Speed Compression**

Low speed compression adjustment is what is typically felt during street driving.



-Begin with the shocks adjusted to the ZERO low speed compression position (full stiff). Do this by rotating the low speed compression adjuster (small knob) clockwise until it stops.

-Now turn the low speed compression adjuster knob counter clock wise 20 clicks. This sets the shock at 20. (settings 21-24 are typically too soft for street use). Take the vehicle for a test drive.

-if you are satisfied with the ride quality, do not do anything, you are set!

-if the ride quality is too soft increase the damping effect by rotating the low speed compression knob clock wise 3 clicks.

**Take the vehicle for another test drive.**



-if the vehicle is too soft increase the damping effect by rotating the low speed compression knob clock wise 3 additional clicks.

-if the vehicle is too stiff rotate the low speed compression adjustment knob counter clock wise 2 clicks and you are set!

Take the vehicle for another test drive and repeat the above steps until the ride quality is satisfactory.

**Step 3:**

Adjust rebound according to Single Adjustable instructions.

**Note:**

One end of the vehicle will likely reach the desired setting before the other end. If this happens stop adjusting the satisfied end and keep adjusting the unsatisfied end until the overall ride quality is satisfactory.





350 S. St. Charles St. Jasper, In. 47546

Ph. 812.482.2932 Fax 812.634.6632

[www.ridetech.com](http://www.ridetech.com)

**Part # 30314100**  
**5 Gallon AirPod Compressor System**  
with LevelPro Controller

- 1 5 gallon AirPod
- 1 31398002 RidePro Digital Display
- 2 6-32 x 3/8" Phillips pan head screw for display
- 1 31900031 Display Harness
- 1 WIR External power harness
- 1 90001924 Fuse holder
- 1 90001920 40 amp fuse
- 1 #10 Yellow butt connector
- 1 #10 5/16" eye connector
- 2 31940002 30' roll of 1/4" airline
- 4 31954201 1/4"npt x 1/4"airline fitting
- 1 Installation Guide

**airpod**<sup>TM</sup>  
by Air Ride Technologies



350 S. St. Charles St. Jasper, In. 47546  
Ph. 812.482.2932 Fax 812.634.6632

[www.ridetech.com](http://www.ridetech.com)

**Part # 30400034**  
**4 Pack of LevelPro Height Sensors**

4	31980002	Rotary height sensor
4	31980001	Linkage kit for height sensor
2	31900046	13' height sensor cord
2	31900047	18' height sensor cord
10	90002030	Heavy duty heat shrink tube - for rubber rod ends



350 S. St. Charles St. Jasper, In. 47546  
Ph. 812.482.2932 Fax 812.634.6632

[www.ridetech.com](http://www.ridetech.com)

**Part # 31008500**  
**RidePro Digital Remote Control kit**

1	31900039	Remote module
2	31900042	Key Fob
1	31900041	Antenna
1	31900001	Module to control panel USB cable